

NOSE GEAR DETAIL

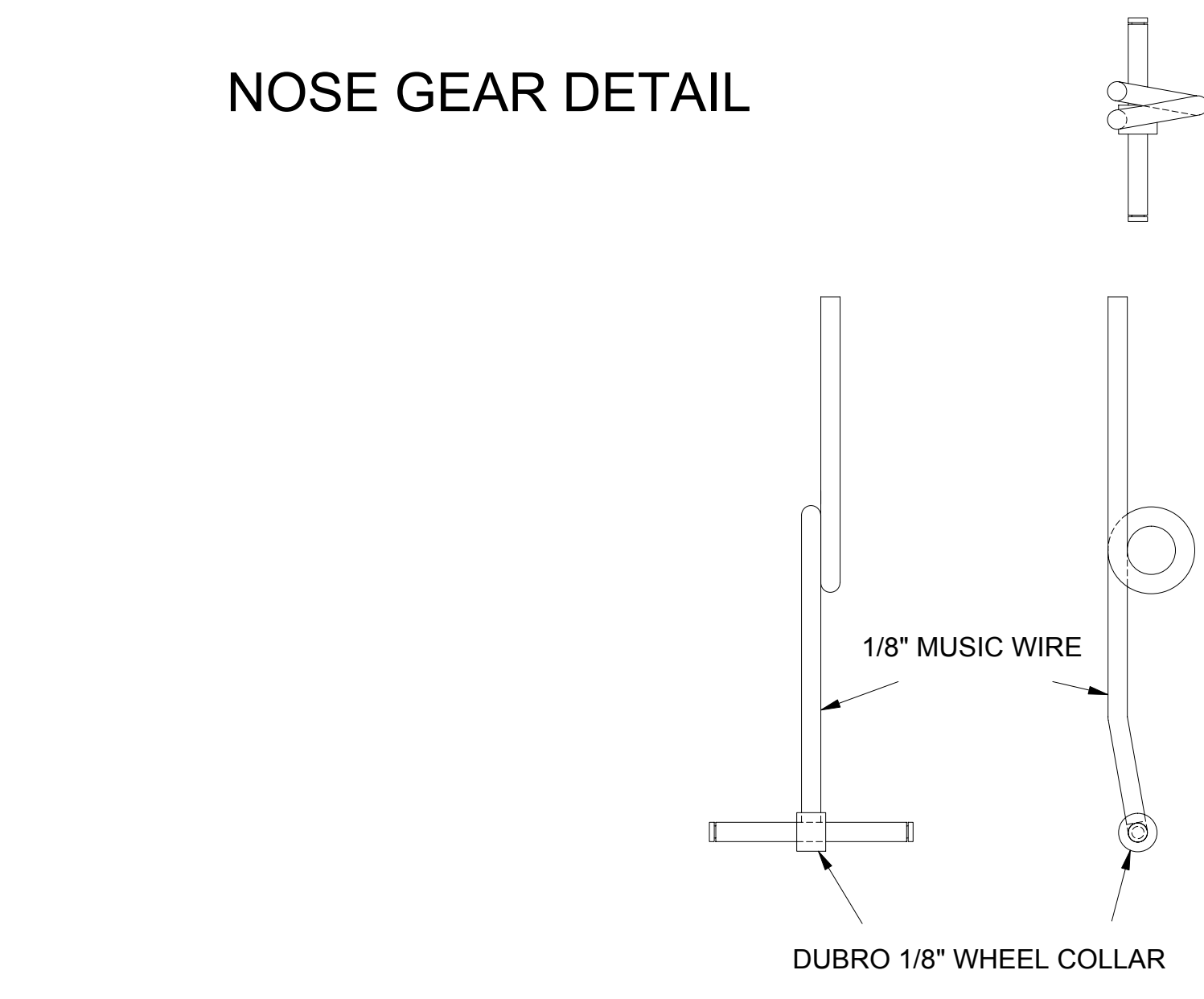

NOSE LG

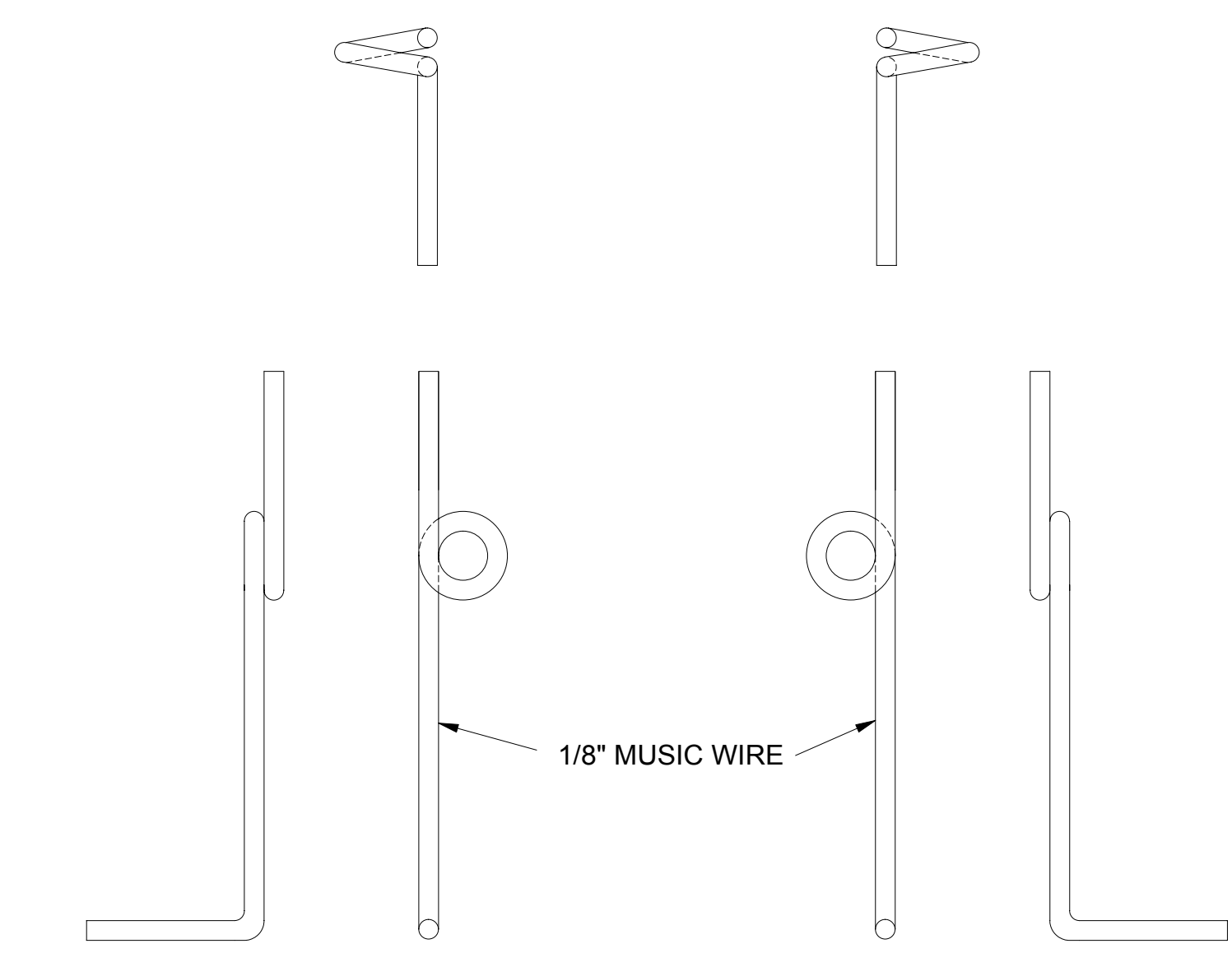

STARBOARD MAIN LG PORT MAIN LG

**MODEL SPECIFICATIONS**  
 SCALE: 1:10.7  
 LENGTH: 48-1/2 IN.  
 WINGSPAN: 28 IN.  
 WING AREA: 390 SQ. IN.  
 NUMBER OF CHANNELS: 3 - 5 (ELEVONS, THROTTLE, RETRACTS, NOSE WHEEL STEERING)  
 FAN SIZE: 70MM (TRACTOR OR WM400)  
 READY-TO-FLY WEIGHT: 48-64 OZ.  
 WING LOADING: 17-23 OZ./SQ. FT.  
 POWER RANGE: 350-800W

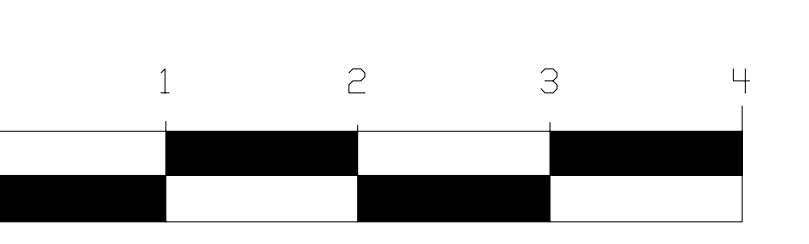

**SAVAGE LIGHT INDUSTRIES**

SCALE: 1:1  
 TITLE: F-106 Delta Dart  
 DATE: 10/19/2008  
 DESIGNED AND DRAWN BY: Dan Savage  
 ALL RIGHTS RESERVED  
 DRAWING NUMBER: 1 OF 3

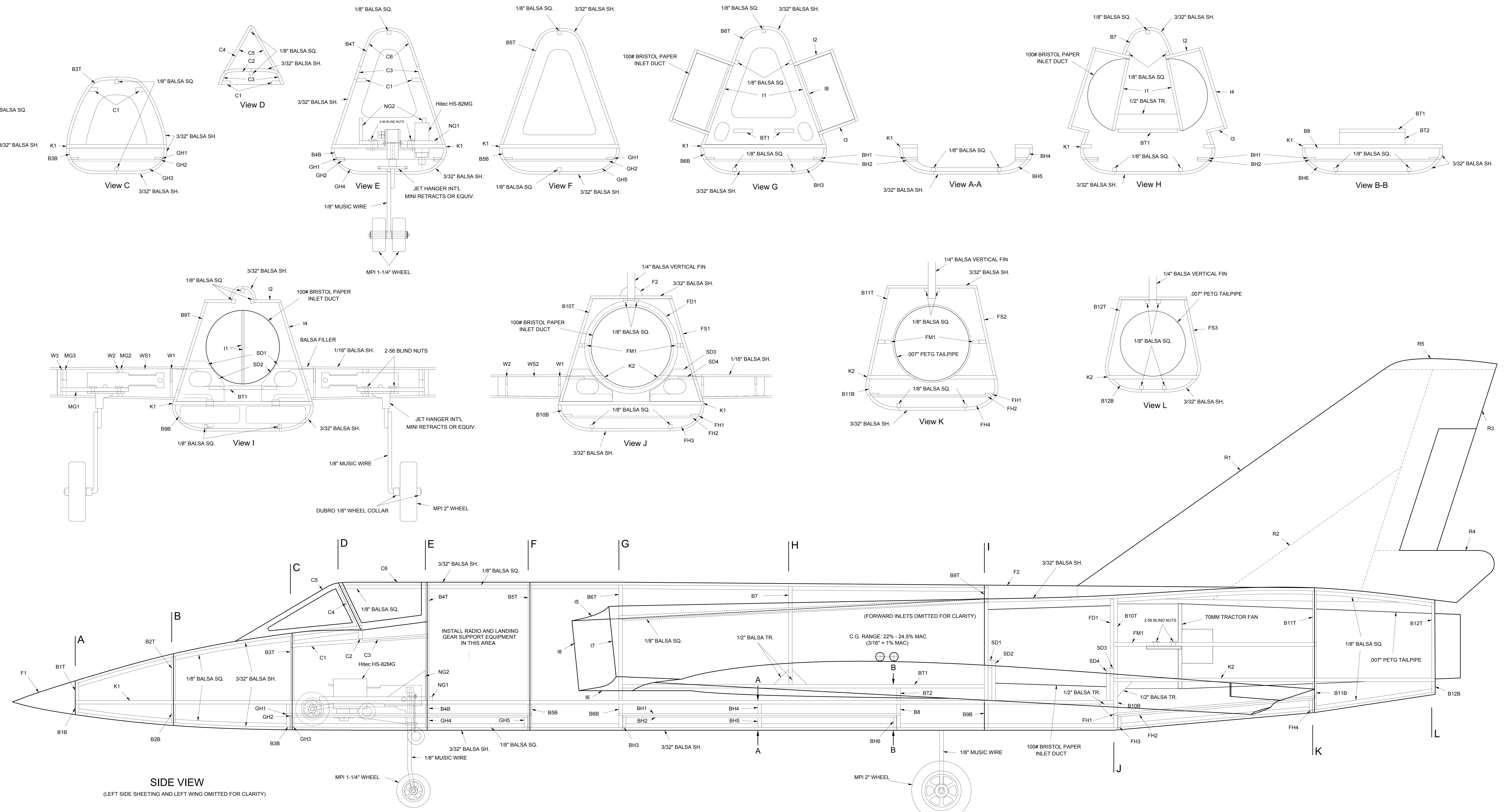

SIDE VIEW  
 (LEFT SIDE SHEETING AND LEFT WING OMITTED FOR CLARITY)

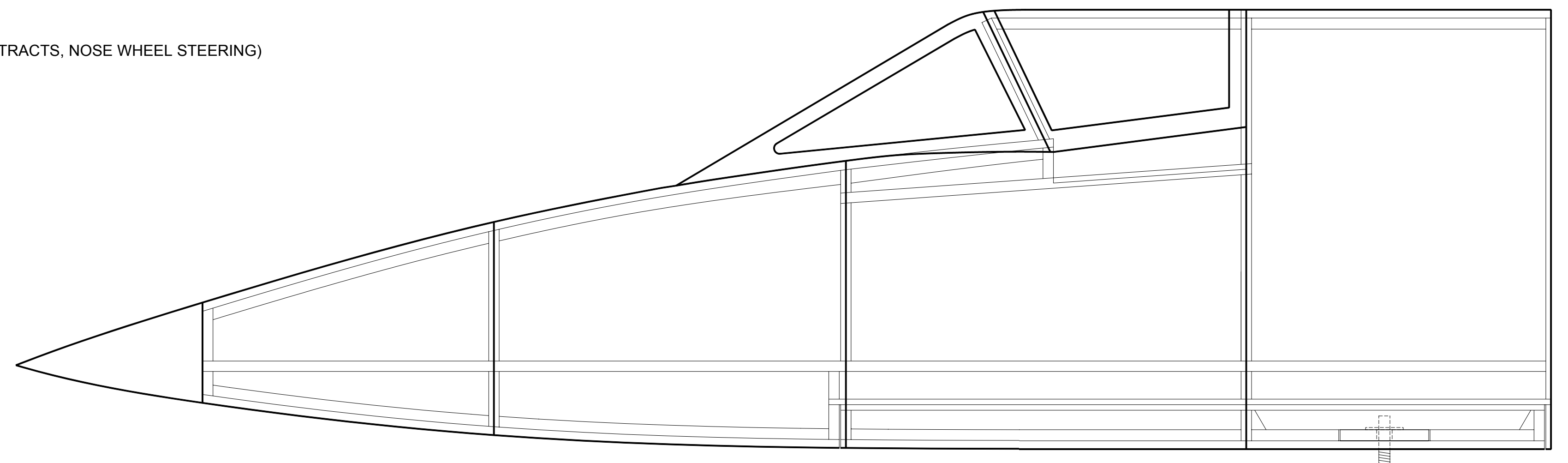

BUNGEE HOOK INSTALLATION

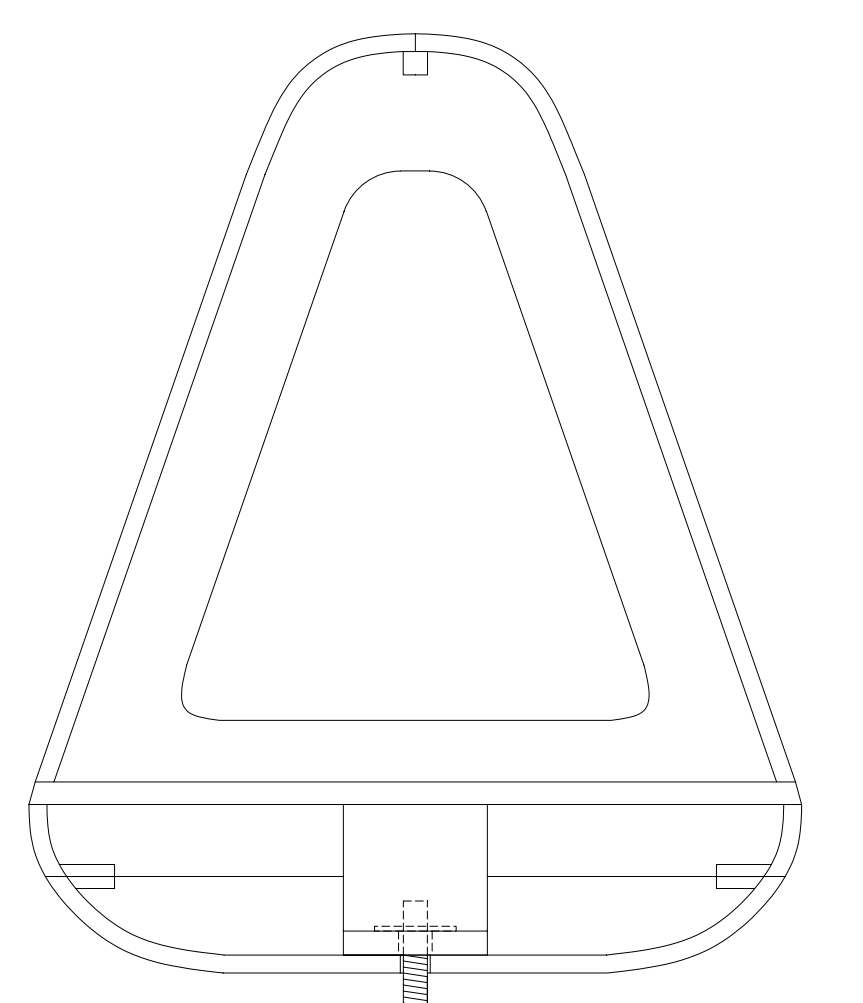

BUNGEE MOUNT

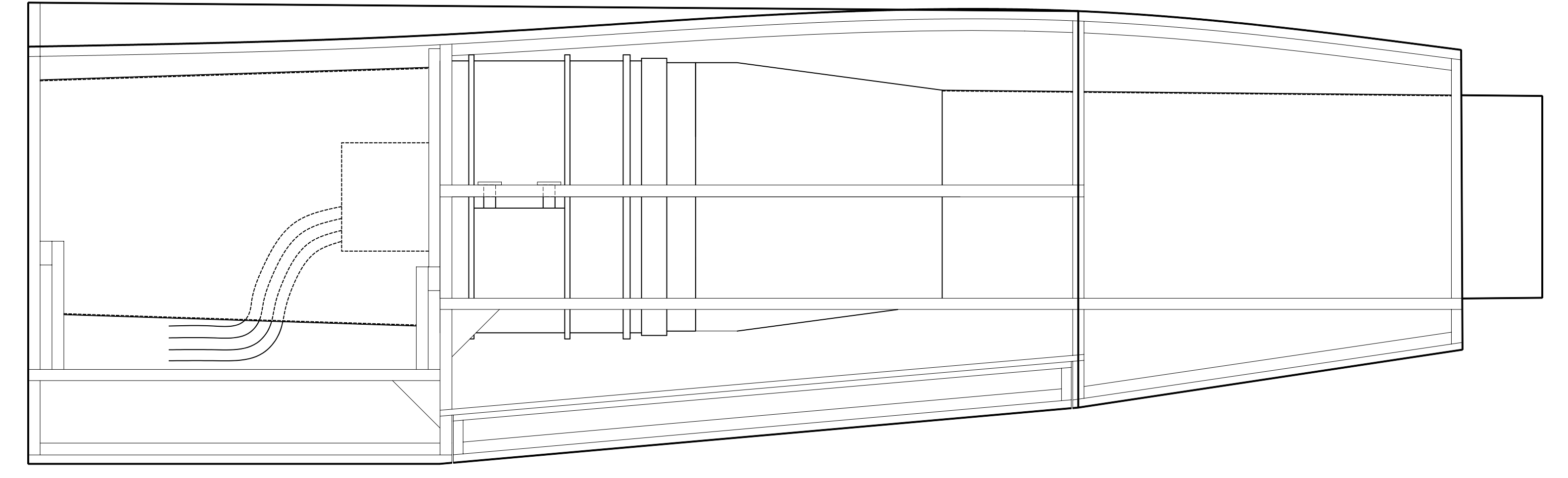

WM400 FAN INSTALLATION

COPYRIGHT (C) 2008 DAN SAVAGE - ALL RIGHTS RESERVED

